

Spare parts list and
Operator's Instructions for
Automatic spray gun

**Ecco 72AS,
Ecco 72ASC**

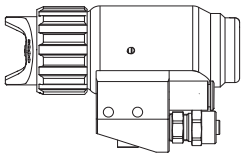

ESL 12/03-71



**Ecco 72AS
with mounting plate**



**Ecco 72ASC
with mounting plate
with circulation**

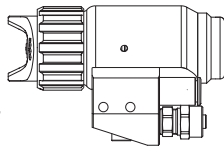

**Ecco 72AS (CNC)
with mounting plate
and click needle stroke control**

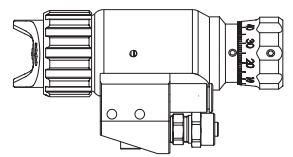
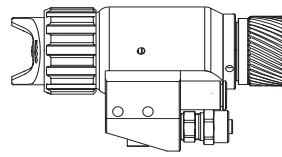

**Ecco 72AS (MNC)
with mounting plate
and micrometric needle stroke control**

Automatic spray gun Ecco 72AS, -72ASC

Ecco 72AS (without circulation) Prod. No. 8611 7260 -01....-99

Ecco 72ASC (with circulation) Prod. No. 8611 7262-01....-99

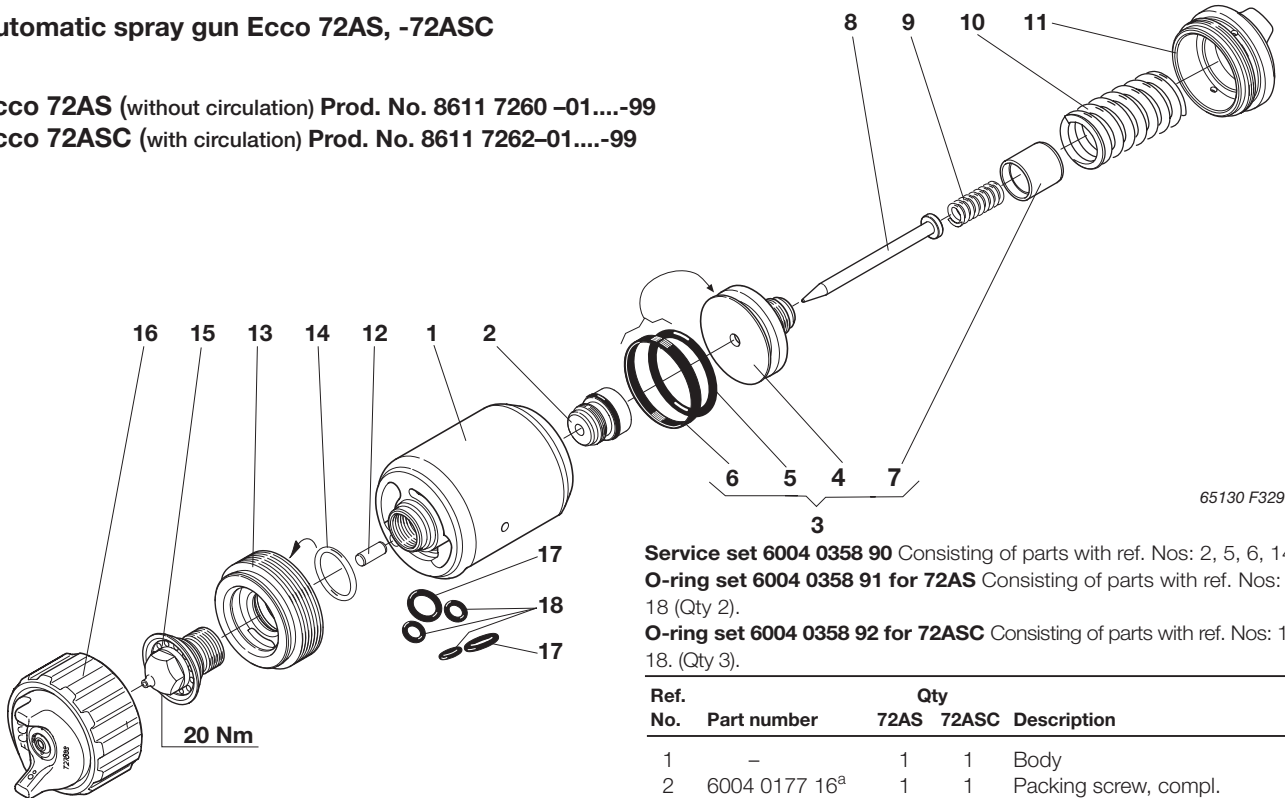

65130 F329

Service set 6004 0358 90 Consisting of parts with ref. Nos: 2, 5, 6, 14.
O-ring set 6004 0358 91 for 72AS Consisting of parts with ref. Nos: 17, 18 (Qty 2).
O-ring set 6004 0358 92 for 72ASC Consisting of parts with ref. Nos: 17, 18. (Qty 3).

Ref. No.	Part number	Qty		Description
		72AS	72ASC	
1	-	1	1	Body
2	6004 0177 16 ^a	1	1	Packing screw, compl.
3	6004 0355 21	1	1	Piston assembly
4	-	1	1	- Piston
5	- ^a	1	1	- O-ring (21.82 x 3.53 Viton)
6	- ^a	1	1	- Glyd ring
7	-	1	1	- Cap
8	(see table at the side)	1	1	Paint needle
9	6003 5789 00	1	1	Spring
10	6003 5794 46	1	1	Spring
11	6004 0355 11	1	1	Cover
12	0101 4131 00	1	1	Pin (CP 4 X 10)
13	6102 1214 00	1	1	Air distributor, compl.
14	6101 1724 00 ^a	1	1	- O-ring (PTFE)
15	-	1	1	Paint nozzle (see spare parts list No. 9836 4148 01 ESL12/04-36)
16	-	1	1	Air cap (see spare parts list No. 9836 4148 01 ESL12/04-36)
17	- ^b	2	2	O-ring (7.66 x 1.78 Viton ETP)
18	- ^{b c}	2	3	O-ring 4.5 x 15 Viton ETP)
Optional equipment				
-	6004 0356 62	1	-	Mounting plate (see page 2)
-	6004 0356 63	-	1	Mounting plate (see page 2)
-	6004 0176 45	1	1	Click needle stroke control (see page 2)
-	6004 0355 15	1	1	Micrometric needle stroke control (see page 3)

Paint needle		
Nozzle set Ø mm	Stainless steel	Part number
0.3 ↓ 1.1	A004XX HA004XX ^a	6004 0348 98 6004 0348 88
1,2 ↓ 2,7	A04XX HA04XX ^a	6004 0348 96 6004 0348 86

^a The letter "H" before the designation denotes tungsten-carbide design tip.

Paint nozzle	Air cap
Complete gun is delivered assembled and tested with nozzle and air cap on. All nozzle and air cap combinations available in ESL 9836 4148 01 ESL 12/04-36	

^aIncluding in service set 6004 0358 90.

^bIncluding in O-ring set 6004 0358 91.

^cIncluding in O-ringset 6004 0358 92.



Optional equipment

6004 0356 62 Ecco 72AS Mounting plate

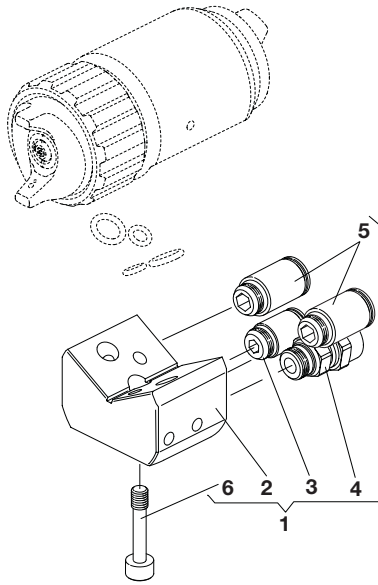

65130 F332

Service set

Coupling set 6004 0358 93 Consisting of parts with ref. Nos: 3, 4, 5 Qty 2).

Ref. No.	Part number	Qty	Description
1	6004 0356 62	1	Mounting plate assembly
2	-	1	- Mounting plate
3	- ^a	1	- Coupling (G1/8-6/4)
4	- ^a	1	- Coupling (G1/8-8/6)
5	- ^a	1	- Coupling (G1/8-8/6)
6	6004 0356 14	1	- Screw (MC6S 5 x 25 A2)

^a Including in service set 6004 0358 93.

6004 0356 63 Ecco 72ASC Mounting plate with circulation

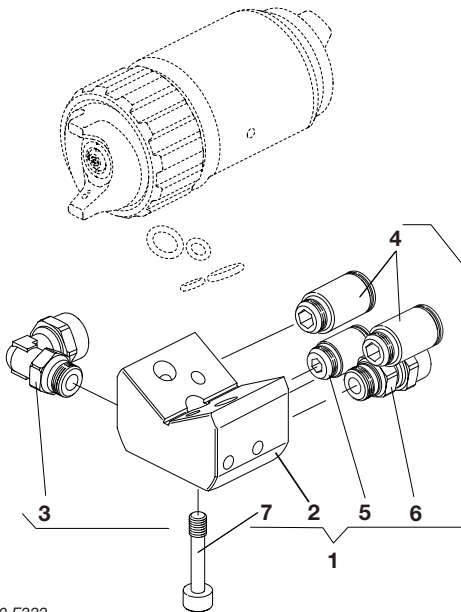

65130 F333

Service set

Coupling set 6004 0358 94 Consisting of parts with ref. Nos: 3), 4 (Qty 3), 5, 6.

Ref. No.	Part number	Qty	Description
1	6004 0356 63	1	Mounting plate assembly
2	-	1	- Mounting plate
3	- ^a	2	- Elbow (G1/8 x 8/6)
4	- ^a	2	- Coupling (G1/8-8/6)
5	- ^a	1	- Coupling (G1/8-6/4)
6	- ^a	1	- Coupling (G1/8-8/6)
7	6004 0356 14	1	- Screw (MC6S 5 x 25 A2)

^a Including in service set 6004 0358 94.

6004 0176 45 Click needle stroke control (CNC)

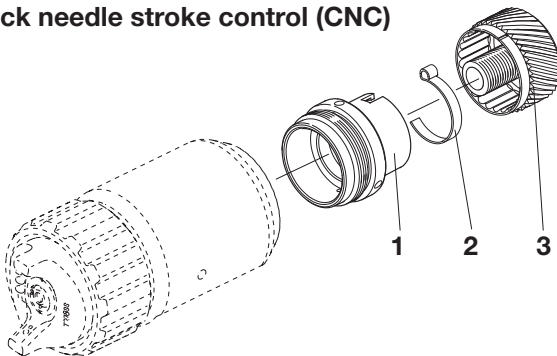

65130 F330

Ref. No.	Part number	Qty	Description
1	-	1	Spring housing
2	6003 5791 68	1	Lock spring
3	-	1	Control knob

Optional equipment

6004 0355 15

Micrometric needle stroke control (MNC)

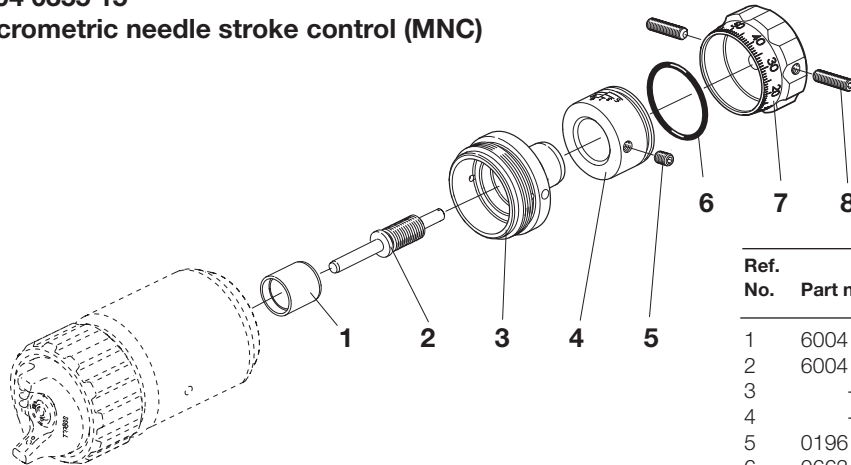

Ref. No.	Part number	Qty	Description
1	6004 0355 18	1	Cap
2	6004 0355 17	2	Set screw
3	-	1	Spring housing
4	-	2	Sleeve
5	0196 1552 07	1	Screw (M4 x 6)
6	0663 9153 00	1	O-ring (23.52 x 1.8)
7	-	1	Control knob
8	0196 1552 09	2	Screw (M4 x 14)

65130 F331

Automatic spray gun Ecco 72AS, -72ASC

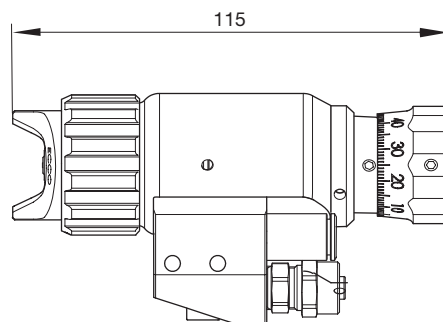
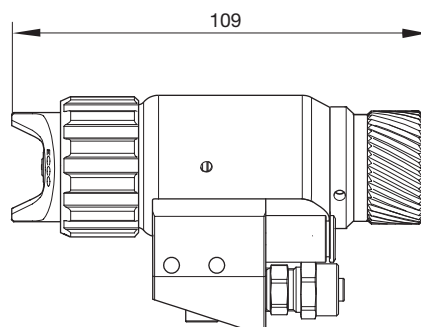
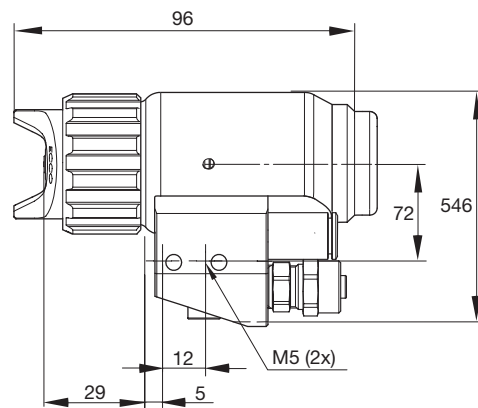
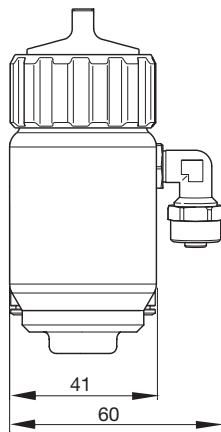
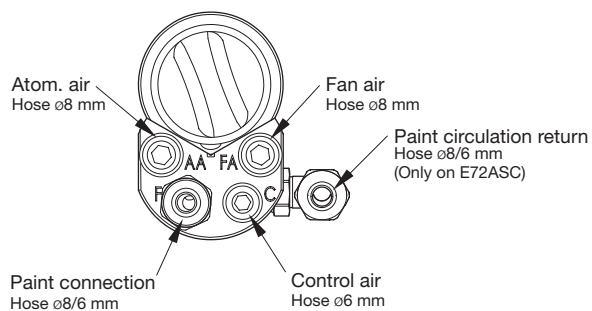

Measurements in millimetres

65130 F334

Operators instructions

Automatic air spray gun used for spraying of wet paint under low pressure.

- All parts for the gun has been tested and certified for optimum performance and can only be replaced with genuine spare parts to maintain the total performance.
- Before starting, read through all instructions carefully.

Principal data

Type	Max. working fluid pressure bar	Max. flushing pressure bar	Min./max. air operation pressure bar
Ecco			
52AS	7	7	4/10



WARNING

As the equipment works under pressure the utmost care must be observed during the work. Bearing this in mind, never aim the spray gun at a person or towards any part of the body. In the event of personal injury caused by the spraying pressure, immediate medical attention is essential. Before carrying out any adjustment or repair, the equipment must be switched off and the paint pressure relieved.

Important



WARNING

Do not use halogenated hydrocarbons in coating application equipment where aluminium or galvanized parts come in contact with the solvent or coating material. Halogenated hydrocarbons e.g. 1,1,1-trichloroethane and methylene chloride react, violently with such parts, causing corrosion and danger for explosion.



WARNING

The high velocity flow of air and liquids through hoses and nozzles may develop static electricity. Be sure that the equipment, object being sprayed, spraybooth, paint and waste container are properly grounded to prevent static discharge or sparks.



S Återvinning

ECCO Finishing AB jobbar för en hållbarare global miljö, därför vill vi att förbrukad produkt återvinns på bästa sätt. Detta görs lämpligast genom att skicka tillbaka den förbrukade produkten till ECCO Finishing AB (paketet märkt med "Återvinning"), eller om möjlighet finnas att demontera produkten och källsortera delarna enligt gällande föreskrifter.

Retur adress:

ECCO Finishing AB Att. Återvinning
Afsengatan 6532 37 Skara
Sweden

D Recycling

ECCO Finishing AB bemüht sich um nachhaltigen Umgang mit Ressourcen und Umweltschutz. Deshalb möchten wir sicherstellen, dass Produkte und Materialien in der bestmöglichen Weise recycelt werden. Deshalb bieten wir die Möglichkeit der Rücksendung von 'verbrauchten' Produkten zum Recyclen an. Bitte demontieren Sie die Produkte soweit es möglich ist, und sende diese in einem Paket mit der Kennzeichnung 'Recycling' an uns zurück.

Rücksendeanschrift:

ECCO Finishing AB Att. Recycling Afsengatan 6
532 37 Skara Sweden



WARNING

The spray gun must be earthed to prevent any electrostatic discharge.
This can be done through the mounting or air/fluid hoses.
A resistance less than 10⁶ Ohms is recommended.

Paint spraying



CAUTION

Inhalation of paint, paint dust and solvent is not healthy. Make sure an approved spraybooth is used. The operator must use personal protection-breathing mask or fresh air hood.

Operation

- Install and operate the spray gun according to Fig. **Automatic spray gun Ecco A72AS** page 3. Blow the paint and air hoses clean before connection.
- Check that all connections are tight .
- Keep the spray gun clean and lubricate (waterfree vaseline) moving parts at regular intervals.
- Lubricants for surface-treatment equipment **must not contain silicon.**
- For short standstill periods, for instance over a night, it will suffice to clean the air and paint nozzles on the outside. If a two-component paint is used, however, the gun **must be flushed through immediately** with solvent. This must also be done if the gun is to remain unused for a longer period of time.
- When cleaning the air cap and the paint nozzle use a soft brush dipped in clean solvent. Do not place the entire gun in solvent, as the oil on the lubricated parts would be dissolved. Blow the air cap dry with compressed air from both sides.
- Never use iron or steel wire to clean air holes and ducts in the nozzles.
- When assessing the reaction time of the connected spray gun (the time from the start impulse until spraying commences) the reaction time of the control valve must be taken into consideration.
- Recommend size for control valve:
 - Control valve, 3-way, G 1/4. Min. flow area 28 mm². Mechanically, pneumatically or electrically actuated.