



Twistork® Helix Agitator

3A4800D
EN

For use in closed-head, bung-type, 55-gallon drums. Radial piston pneumatic motor driven agitators for maintaining suspension and even-mixing in industrial paints and coatings. For professional use only.



Important Safety Instructions

Read all warnings and instructions in this manual before using the equipment. Save these instructions.

*70 psi (0.5 MPa, 5 bar) Maximum
Recommended Operating Pressure*

*See page 3 for model part numbers and
approvals information.*

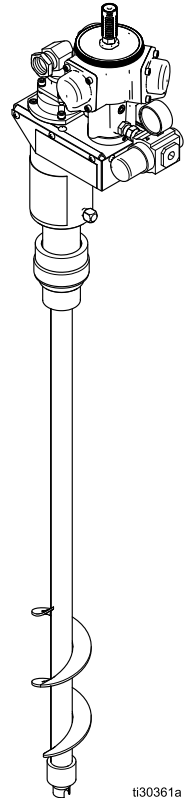

t30361a



Contents

Model	2	Air Motor Muffler	11
Warnings	3	Inspecting the Drive Belt.....	11
Application	5	Cleaning the Air Intake Check Valve	11
Installation.....	6	Correcting a Bad Suction Line Seal.....	12
Remote Mount Pump	6	Prolonging the Life of the Seal Bearing.....	12
Air Regulator and Mufflers	7	Cleaning the Fluid Tubes.....	13
Installing the Agitator.....	8	Service	14
Grounding	9	Removing the Air Motor.....	14
Air Line Accessories.....	9	Removing the Drive Belt.....	14
Air Requirements	9	Removing Siphon and Helix Tubes.....	15
Operation.....	10	Assembling the Agitator.....	16
Agitator Operation.....	10	Parts.....	17
Pressure Relief Procedure.....	10	Dimensions	19
Nitrogen Charge the Drum.....	10	Air Consumption.....	20
Maintenance	11	Technical Specifications.....	21
Greasing the Air Motor	11	California Proposition 65.....	21

Related Manuals





Manual No.	Description
3A4792	Air-Driven Agitators
3A4797	Stainless Steel, Air-Driven Agitators with Pressure Tank
3A5050	Agitator Air Motor Rebuild Kits

Model

Part No.	Description	Approvals		
25C-532	Belt Driven, Stainless Steel, Pneumatic Twistork Helix Agitator with Suction Feature	 2575	 0359	 II 1/2 G Ex h IIB T4 Ga/Gb IECEx ETL 17.0019 ITS17ATEX1001809 ITS21UKEX0387 0°C ≤ Tamb ≤ 50°C

Warnings

The following warnings are for the setup, use, grounding, maintenance, and repair of this equipment. The exclamation point symbol alerts you to a general warning and the hazard symbols refer to procedure-specific risks. When these symbols appear in the body of this manual, refer back to these Warnings. Product-specific hazard symbols and warnings not covered in this section may appear throughout the body of this manual where applicable.

 <h2 style="margin: 0;">WARNING</h2>	
	<p>FIRE AND EXPLOSION HAZARD</p> <p>Flammable fumes, such as solvent and paint fumes, in work area can ignite or explode. Paint or solvent flowing through the equipment can cause static sparking. To help prevent fire and explosion:</p> <ul style="list-style-type: none"> • Use equipment only in well ventilated area. • Eliminate all ignition sources; such as pilot lights, cigarettes, portable electric lamps, and plastic drop cloths (potential static arc). • Ground all equipment in the work area. See Grounding instructions. • Never spray or flush solvent at high pressure. • Keep work area free of debris, including solvent, rags and gasoline. • Do not plug or unplug power cords, or turn power or light switches on or off when flammable fumes are present. • Use only grounded hoses. • Hold gun firmly to side of grounded pail when triggering into pail. Do not use pail liners unless they are antistatic or conductive. • Stop operation immediately if static sparking occurs or you feel a shock, Do not use equipment until you identify and correct the problem. • Keep a working fire extinguisher in the work area.
	<p>MOVING PARTS HAZARD</p> <p>Moving parts can pinch, cut, or amputate fingers and other body parts.</p> <ul style="list-style-type: none"> • Keep clear of moving parts. • Do not operate equipment with protective guards or covers removed. • Do not wear loose clothing, jewelry, or long hair while operating equipment. • Equipment can start without warning. Before checking, moving, or servicing equipment, follow the Pressure Relief Procedure and disconnect all power sources.
	<p>PRESSURIZED EQUIPMENT HAZARD</p> <p>Fluid from the equipment, leaks, or ruptured components can splash in the eyes or on skin and cause serious injury.</p> <ul style="list-style-type: none"> • Follow the Pressure Relief Procedure when you stop spraying/dispensing and before cleaning, checking, or servicing equipment. • Tighten all fluid connections before operating the equipment. • Check hoses, tubes, and couplings daily. Replace worn or damaged parts immediately.



WARNING



EQUIPMENT MISUSE HAZARD

Misuse can cause death or serious injury.



- Do not operate the unit when fatigued or under the influence of drugs or alcohol.
- Do not exceed the maximum working pressure or temperature rating of the lowest rated system component. See **Technical Specifications** in all equipment manuals.
- Use fluids and solvents that are compatible with equipment wetted parts. See **Technical Specifications** in all equipment manuals. Read fluid and solvent manufacturer's warnings. For complete information about your material, request SDS from distributor or retailer.
- Do not leave the work area while equipment is energized or under pressure.
- Turn off all equipment and follow the **Pressure Relief Procedure** when equipment is not in use.
- Check equipment daily. Repair or replace worn or damaged parts immediately with genuine manufacturer's replacement parts only.
- Do not alter or modify equipment. Alterations or modifications may void agency approvals and create safety hazards.
- Make sure all equipment is rated and approved for the environment in which you are using it.
- Use equipment only for its intended purpose. Call your distributor for information.
- Route hoses and cables away from traffic areas, sharp edges, moving parts, and hot surfaces.
- Do not kink or over bend hoses or use hoses to pull equipment.
- Keep children and animals away from work area.
- Comply with all applicable safety regulations.



TOXIC FLUID OR FUMES HAZARD

Toxic fluids or fumes can cause serious injury or death if splashed in the eyes or on skin, inhaled, or swallowed.



- Read Safety Data Sheet (SDS) to know the specific hazards of the fluids you are using.
- Store hazardous fluid in approved containers, and dispose of it according to applicable guidelines.



BURN HAZARD

Equipment surfaces and fluid that is heated can become very hot during operation. To avoid severe burns:

- Do not touch hot fluid or equipment.



PERSONAL PROTECTIVE EQUIPMENT

Wear appropriate protective equipment when in the work area to help prevent serious injury, including eye injury, hearing loss, inhalation of toxic fumes, and burns. Protective equipment includes but is not limited to:

- Protective eyewear, and hearing protection.
- Respirators, protective clothing, and gloves as recommended by the fluid and solvent manufacturer.

Application

The Twistork Helix Agitator is intended for mixing and maintaining paints and similar fluids in closed-head, 55-gallon (200-liter) drums with 2-inch npt bung connections. It provides suction porting through its siphon tube, which allows fluid siphoning to a pump while mixing.

When the helix operates in a counterclockwise direction it mixes fluid by lifting it up from the bottom of the drum. This center-lift fluid rotation is preferred in most applications because it minimizes fluid aeration.

When rotation is reversed, the agitator operates in a pull-down fluid rotation mode, which can be better for agitating fluids that are difficult to put into suspension. With clockwise (pull-down fluid rotation), care must be used at high speeds to prevent cavitation, which could be caused by air being drawn down to the siphon inlet.

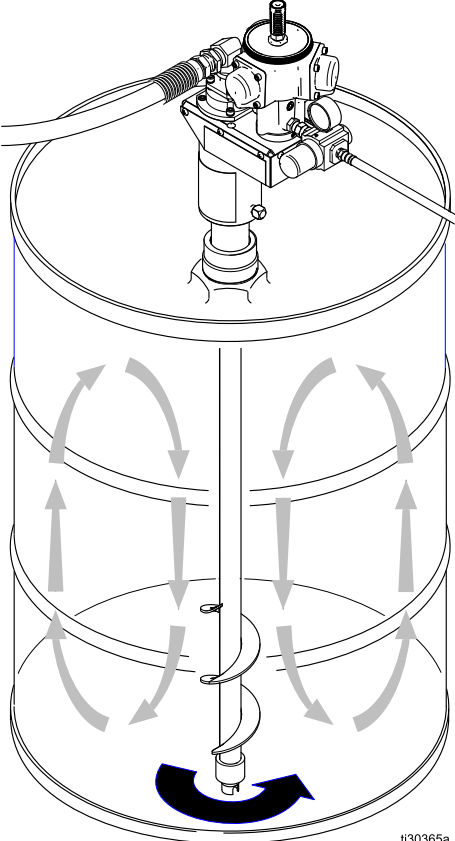

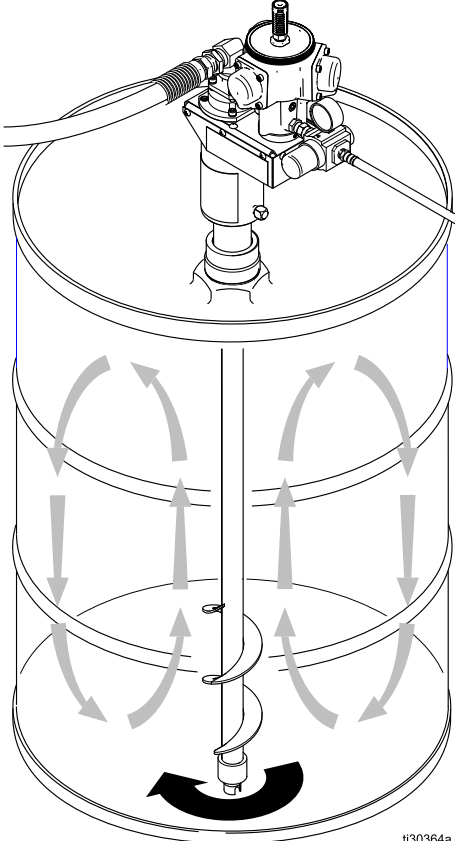

Counterclockwise Rotation



Clockwise Rotation

Installation

				
<p>To reduce the risk of fire and explosion, always maintain a minimum of 1 in. (25.4 mm) clearance between the rotating agitator parts and the container to prevent sparks from contact.</p>				

NOTE: Throughout the manual, reference numbers and letters in parentheses refer to callouts in figures and the parts drawing. See [Parts, page 17](#).

See below for a typical installation. See [Air Line Accessories, page 9](#) for information on parts not included with your agitator.

Table 1 Typical Installation

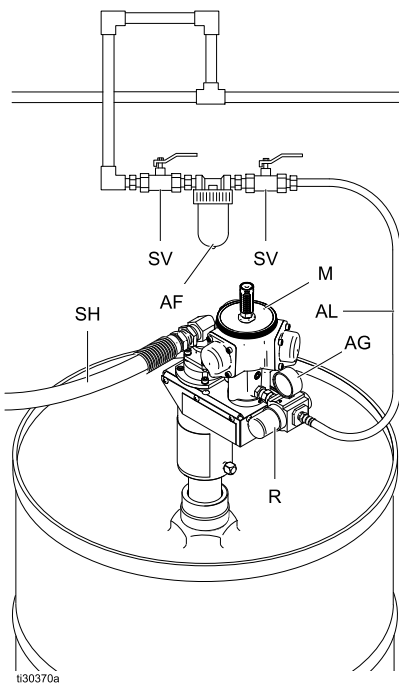

Reference	Description
SV	Shutoff Valve
AF	Air Line Filter
M	Motor
AL	Air-in Line
AG	Air Pressure Gauge
R	Regulator
SH	Suction Hose

Remote Mount Pump

To avoid damaging the agitator, do not mount the pump (P) directly to the agitator outlet fitting (41). Make sure the pump is properly supported, and install a flexible suction hose (SH) between the agitator outlet fitting and the pump.

Table 2 Remote Mount Pump

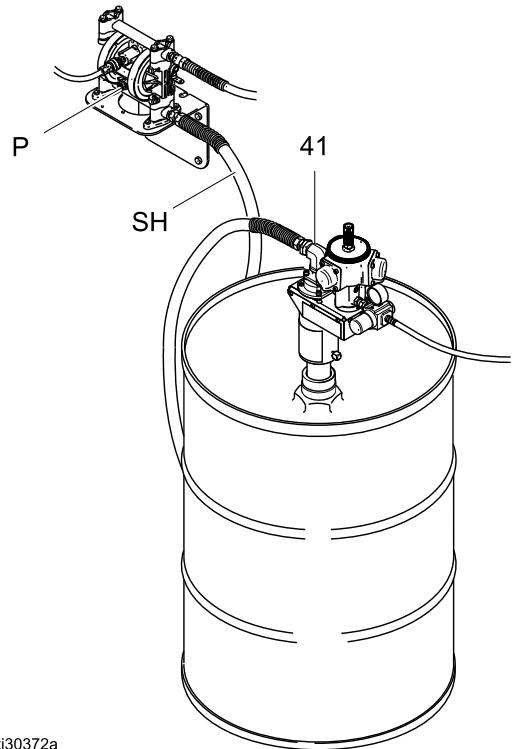

ti30372a

Reference	Description
SH	Suction Hose
P	Pump
41	Agitator Outlet Fitting

Air Regulator and Mufflers

The air motor is capable of operating in a clockwise or counterclockwise direction, depending on where the air regulator is mounted.

- When the air regulator is installed in one of the two lower ports on the motor, a clockwise rotation results, as viewed from the top of the motor.
- When installed on either side in one of the two upper ports, a counterclockwise rotation results.
- The port opposite the regulator must be plugged for the motor to operate.

The air regulator, mufflers, air gauge, nipple connector, and swivel connector are not factory installed. Follow the directions below to install these items:

1. Screw the swivel connector (F) into the desired port (upper or lower) in the motor (K).
2. Screw the nipple connector (G) into the air regulator (H) outlet. Note the arrow directions on the regulator.

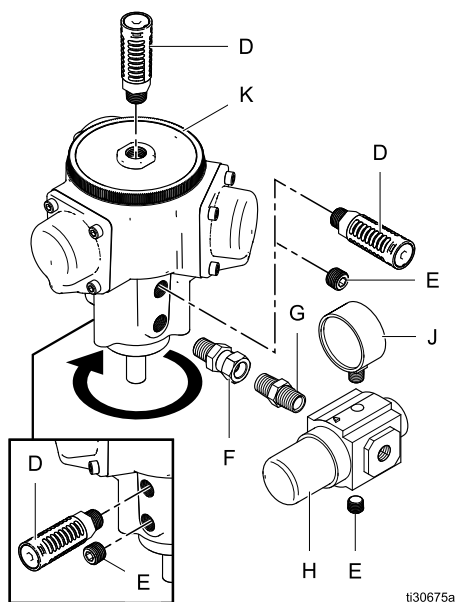

ti30675a

3. Attach the air regulator by screwing it into the swivel connector.
4. Install a plug (E) in the port opposite the regulator (this is necessary for motor operation).
5. Attach the air gauge (J) by screwing it into the hole in the top of the air regulator.
6. Install a plug (E) in the regulator in the port opposite the air gauge.
7. Screw one muffer (D) into the top of the motor.
8. Screw the second muffer into the open port on the far side of the motor from the regulator.
9. Install the third muffer in the open port above or below the regulator. An additional fitting may be needed (not provided) to space the regulator farther away from the motor.

NOTE: Use of the third muffer is not necessary, but is beneficial for increased air circulation in humid conditions. If a third muffer is not used, the hole must be plugged (E).

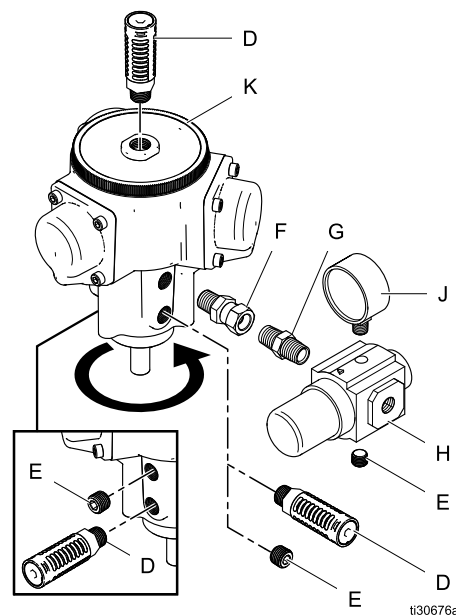

ti30676a

Air regulator installation for clockwise agitator rotation.

Air regulator installation for counterclockwise agitator rotation.

Reference	Description
D	Mufflers
E	Plugs
F	Swivel connector
G	Nipple connector
H	Agitator air regulator
J	Air gauge
K	Air motor

Installing the Agitator

NOTICE

To avoid damaging the siphon tube, lower the agitator to the drum bottom; do not drop it.

NOTICE

Do not install the siphon tube without the seal bearing in place. If the seal bearing is not in place, the siphon tube and helix tube can rub against each other during operation, resulting in equipment damage. Replace the seal bearing if damaged or worn.

1. Be sure the seal bearing (8) is in place before installation.

NOTE: The seal bearing is made of acetal, which is not compatible with some of the solvents used in paints or coatings and is not compatible with acidic fluids. An optional RulonR seal bearing Part No. 189660 is available. Check your material data sheet or supplier for compatibility.

2. Hold the agitator by the housing (3). Lower the helix tube (7) through the bung using a turning motion until the siphon tube rests on the bottom of the drum.

NOTE: The tube must rest on the bottom in order to evacuate the maximum amount of material from the drum and stabilize the agitator.

3. Position the air motor so the air line (AL) easily attaches to the air regulator inlet (19) without obstructing any other system components.
4. Make sure the gasket (46) is in place, screw the bung adapter (44) into the bung, and tighten the bung adapter.
5. Make sure the O-ring (20) is in place inside the O-ring retainer (45), and tighten the O-ring retainer.

Make sure the bung adapter and O-ring retainer are tight in order to keep the helix tube pointed straight down.

6. Attach the air line to the air regulator.

7. When using the agitator suction feature, connect a suction hose (SH) between the agitator fluid outlet fitting (41) and the pump. See [Remote Mount Pump, page 6](#). The hose connector must have a 30-degree bevel to match the fluid outlet fitting with an airtight seal.

When not using the siphon feature, plug the fluid outlet fitting to prevent excess fluid evaporation.

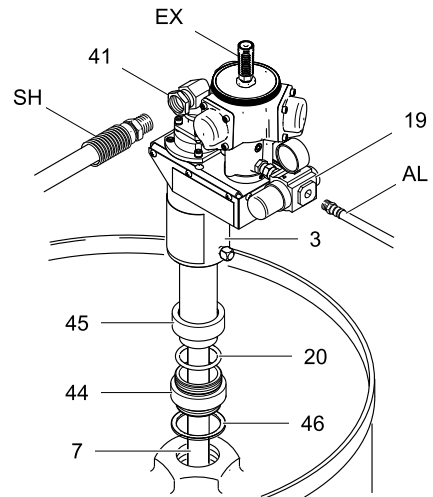

Table 3 Installing the Agitator



ti30373a

Reference	Description
3	Twistork Housing
7	Helix Tube
19	Air Regulator Intake
20	O-Ring
41	Outlet Fitting
44	Bung Adapter
45	O-Ring Retainer
46	Gasket
EX	Vent
AL	Air Line
SH	Suction Hose

Grounding

				
<p>The equipment must be grounded to reduce the risk of static sparking. Static sparking can cause fumes to ignite or explode. To reduce the risk of static sparking, the mounting cover and all electrically conductive objects or devices in the spray area must be properly grounded.</p>				

A ground wire and clamp are not included. For a ground wire and clamp, order part number 222011.

To ground the agitator, connect one end of the ground wire (GW) to the grounding lug (GC). Connect the other end of the ground wire to a true earth ground.

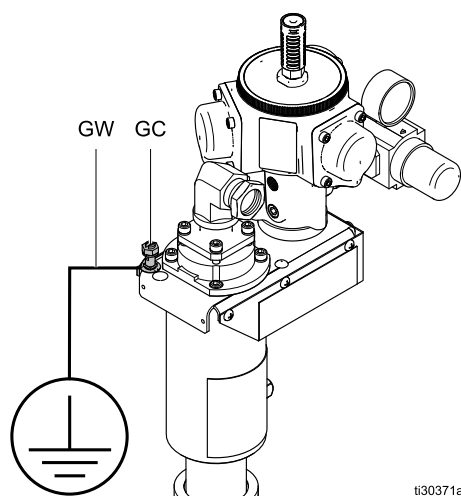

Figure 1 Ground Wire Connection

ti30371a

Air Line Accessories

Install the following accessories in the order shown below, using adapters as necessary.

Air Shut-off Valve

The bleed-type master air shutoff valve isolates the air line components for servicing. An air shut-off valve should be installed in the supply line and used to stop and start the agitator.

Order bleed-type air shut-off valves using the part numbers listed below:

Part Number	Inlet/Outlet npt	Max WPR			Material
		psi	bar	MPa	
110223	1/4 (fxf)	250	17.2	1.7	Brass
110224	3/8 (fxf)	250	17.2	1.7	Brass
110225	1/2 (fxf)	250	17.2	1.7	Brass
110226	3/4 (fxf)	250	17.2	1.7	Brass
113163	1 (fxf)	250	17.2	1.7	Brass
107142	1/2 (mxf)	250	17.2	1.7	Brass
107141	3/4 (mxf)	250	17.2	1.7	Brass

Air Line Filter

Air line filters remove harmful dirt, moisture, and oil from the compressed air supply. Order part 106148 for 3/8 npt or 106149 for 1/2 npt.

Air Requirements

The air motor does not require lubricated air.

See [Air Consumption, page 20](#) for requirements.

Connect the supply air to the inlet side of the air regulator.

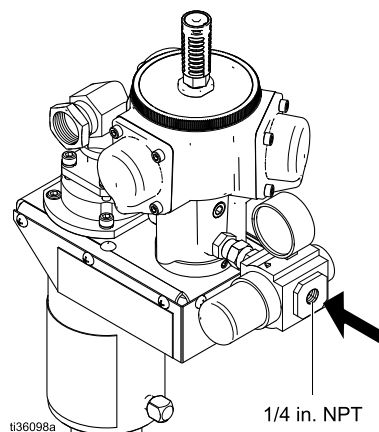





Figure 2 Supply Air Connection

Operation

				
<p>Personal injury, such as splashing in the eyes, may result from pressure in the tank. Always follow the Pressure Relief Procedure, page 10 before opening the tank cover or fill port.</p> <p>Personal injury or equipment damage may result from lifting/falling heavy equipment. To avoid personal injury or equipment damage:</p> <ul style="list-style-type: none"> Do not lift the drum cover and agitator without proper assistance. Do not walk or stand beneath a raised elevator. 				

NOTICE
<p>Fluids can pass through the seal bearing into the gap between the two tubes. Be sure to keep the tube clean.</p>

Agitator Operation

NOTICE
<p>To avoid damaging the equipment, do not operate the agitator at a high speed for a long period of time. Excessive agitator speed can cause foaming of fluid (making the fluid unusable), vibration, and increased wear on parts. Only agitate the fluid enough to maintain even mixing.</p>





Agitators are used to keep solids in suspension, which assists in keeping solids from clogging the siphon tube. If solids have settled in the container, use a shaker or some other device to thoroughly agitate the fluid before installing and operating the agitator.

The seal bearing (8) helps prevent excessive fluid flow between the siphon tube (4) and helix tube (7), but it is not intended to be a complete seal. Before changing colors or coatings or storing the agitator, clean the tubes as instructed in [Cleaning the Fluid Tubes, page 13](#).

1. Start the agitator by opening the air shutoff valve (A). Regulate the speed with the air regulator knob (F).
2. Operate the agitator continuously when supplying paints or other fluids to the system.
3. Stop the agitator by closing the air shutoff valve or by reducing pressure with the air regulator knob.

NOTE: Do not let fluid dry in the fluid tubes. If the agitator is removed from the drum, remove the seal bearing and hang or tilt the agitator upright over a container to allow it to drain.

Pressure Relief Procedure

				
<p>This equipment stays pressurized until pressure is manually relieved. To help prevent serious injury from splashing fluid and moving parts, follow the Pressure Relief Procedure before cleaning, checking, or servicing the equipment.</p>				

1. Disconnect the air line.
2. Close the bleed-type air shutoff valve (A) to relieve pressure to the air regulator.

Nitrogen Charge the Drum

NOTICE
<p>High air pressure can push fluid through the shaft seal and into the top bearings, damaging them. Be sure to monitor the air pressure.</p>

If you are using nitrogen to charge the drum, use a maximum of 0.25 psi (1.7 kPa, 0.02 bar). Low pressure requires special regulation equipment. Use a passive, non-pressurized system when possible. Higher pressure could push fluid through the shaft seal (21) and into the top bearings (11), damaging them.

Maintenance

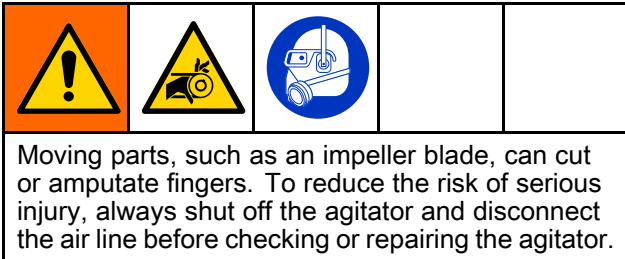

Before performing any maintenance procedure, follow the [Pressure Relief Procedure, page 10](#).

Greasing the Air Motor

After every 20 million revolutions or every three to four months (whichever comes first), grease the motor needle bearing. Recommended grease: MOBILGREASE XHP 222 SPECIAL or equivalent with minimum flash point temperature of 399.2°F (204°C).

1. Follow the [Pressure Relief Procedure, page 10](#).
2. Remove the motor top cover (103).
3. Using a manual grease gun, push grease into the 21RC fitting (102) until grease is seen below the top washer (109a).

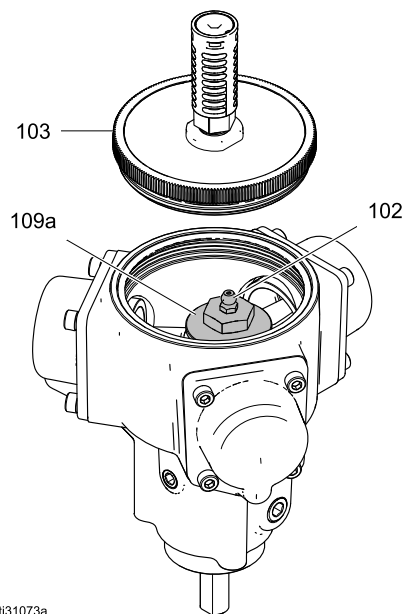

Air Motor Muffler

Depending on the environment of the motor, periodically check the cleanliness of the air motor muffler. Dirty or clogged air mufflers result in decreased motor efficiency and may cause the motor to run irregularly. If the muffler is dirty or clogged, replace it with a new muffler.

Inspecting the Drive Belt

The drive belt (15), the large pulley (13), and the small pulley (12) should be inspected periodically for dirt, rust, damage, and excessive wear. See [Removing the Drive Belt, page 14](#). Clean the large pulley and small pulley as needed and replace if excessively worn or damaged.

NOTICE

Never pry or force the belt over the pulley flange during installation or removal. Damage may occur.

Cleaning the Air Intake Check Valve

The air intake check valve (32, 33, 34) allows make-up air to enter the closed drum as fluid is drawn out through the agitator outlet port.

The air intake check valve should be inspected and cleaned every 2000 operating hours or when there are any signs of the drum beginning to collapse as fluid is drawn out.

Pump priming problems can indicate a plugged air intake check valve. Paint overspray in the air can be drawn into the valve and cause the ball to stick in the closed position.

To clean the air intake check valve:

1. Follow the [Pressure Relief Procedure, page 10](#).
2. Remove the seat (33) and ball (34).
3. Clean the parts with compatible solvent, and reassemble the valve.
4. Insert the ball, and tighten the seat until just snug. The seat should not be flush with the elbow. Installing the seat too tightly could jam the ball against the seat.

Correcting a Bad Suction Line Seal

Air getting pulled into the suction line makes the pump inefficient. This can happen for the following reasons:

- Cavitation is occurring, because the pump or helix is going too fast.
- Siphon hose connection is leaking.
- Nylon rings are not sealing.

To correct the problem:

1. Torque the four socket-head screws (24) in the siphon cover (6) oppositely and evenly to 80 to 100 in-lbs (9.0 to 11.3 N•m).
2. Replace the rings (22). Make sure the outer lips face up, as shown below.
3. Insert the siphon tube (4) into the bottom of the siphon cover.
4. Tap the bottom of the siphon tube to make sure the tube passes through the rings and seats on the siphon cover.
5. Torque the four socket-head screws in the siphon cover oppositely and evenly to 80 to 100 in-lbs (9.0 to 11.3 N•m).

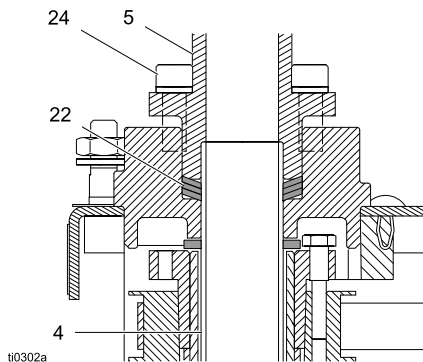

Figure 3 Correcting Bad Suction Line Seal

Prolonging the Life of the Seal Bearing

NOTICE

To prevent equipment damage, use a compatible solvent to clean parts. The seal bearing is made of acetal, which is not compatible with acidic fluids. Check your material data sheet or supplier for compatibility.

NOTICE

To prevent equipment damage, do not allow fluids to dry out in the fluid section. Dry fluid will adhere to the seal bearing and could damage the seal bearing the next time you start the agitator.

Replace the seal bearing if it is damaged or worn.

To extend the life of the seal bearing, do the following:

- Flush the fluid section before you change colors or coatings or store the agitator.
- Do not operate the agitator without fluid in the drum, as this can cause excessive wear to the seal bearing.

Cleaning the Fluid Tubes

Without air circulation, catalyzed materials can harden. Always remove and clean both tubes after mixing or pumping catalyzed materials.

To prevent fluid from drying on the tubes and interfering with helix rotation, clean the siphon and helix tubes when changing colors or coatings and when the agitator is removed from the drum long enough for the fluid to dry. Also, clean the fluid tubes for periodic maintenance as follows:

1. Remove the siphon and helix tubes. See [Removing Siphon and Helix Tubes, page 15](#).
2. Clean the siphon tube (4), helix tube (7), and seal bearing (8). The inside diameter of the tubes can be cleaned by pulling a solvent-soaked rag through them.
3. Apply PTFE spray lubricant to the siphon tube, inlet end only. Install the siphon tube through the top of the drive belt housing (2).
4. Install the two socket-head screws (24) and lock washers (25) into the top of the siphon cover (6). Torque the screws oppositely and evenly to 60 to 70 in-lbs (6.8 to 7.9 N•m).
5. Apply PTFE spray lubricant to the inside lip of the seal bearing (8), and tighten it into the helix tube (7).

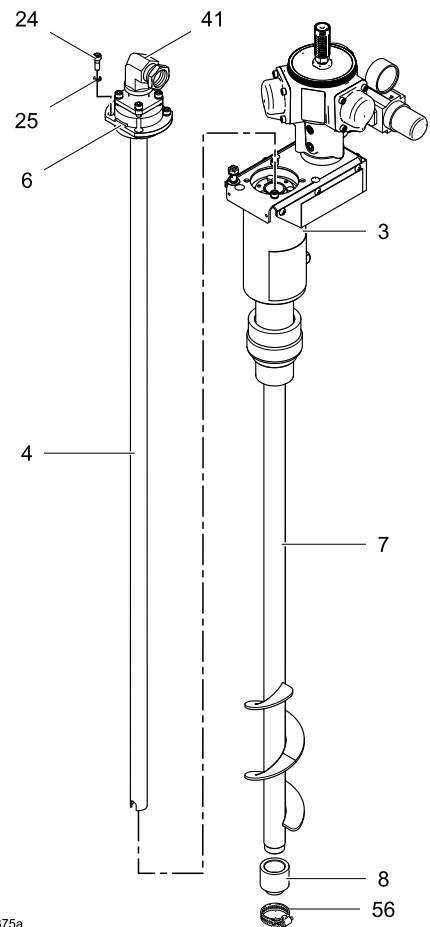

Table 4 Cleaning the Fluid Tubes



ti30375a

Ref.	Description
3	Twistork Housing
4	Siphon Tube
6	Siphon Cover
7	Helix Tube
8	Seal Bearing
24	Screw
25	Washer
41	Union Swivel
56	Hose Clamp

Service

				
<p>Moving parts, such as an impeller blade, can cut or amputate fingers. To reduce the risk of serious injury, always shut off the agitator and disconnect the air line before checking or repairing the agitator.</p>				

NOTICE
<p>Keep the agitator upright. If left on its side or upside down, fluid could flow into the belt-drive area and damage the equipment.</p>

If the agitator is removed from the drum, remove the seal bearing and hang or tilt the agitator upright over a container to allow it to drain.

If the air motor requires more than installation of a service kit, it is usually quickest and easiest to send it to a Graco distributor for repair or replacement.

Motor rebuild kits are available and listed in the table below. See manual 3A5050 for more information.

Kit	Description
25M535	Full air motor rebuild kit
25P720	Needle bearing rebuild kit
25P721	Single piston assembly rebuild kit
25P860	End cap kit
19Y509	Muffler kit (set of 3)

Removing the Air Motor

1. Follow the [Pressure Relief Procedure, page 10](#).
2. Remove the set screw (26) securing the motor.
3. Remove the pan head screws (27) to open the bracket (1).
4. Gently pry the timing belt (15) from the small pulley (12).
5. Lift up on the motor to remove the motor with small pulley.

Removing the Drive Belt

1. Follow the [Pressure Relief Procedure, page 10](#).
2. Remove the eight screws (27) and the drive belt cover (2).
3. Remove the three hex-head screws (14a) and the bushing (14).
4. Slide the drive belt (15) off of the smaller pulley (12), and remove the larger pulley (13) and drive belt.
5. Replace the drive belt if it is cracked or worn with a genuine ESD rated and marked drive belt only.

Table 5 Removing the Drive Belt

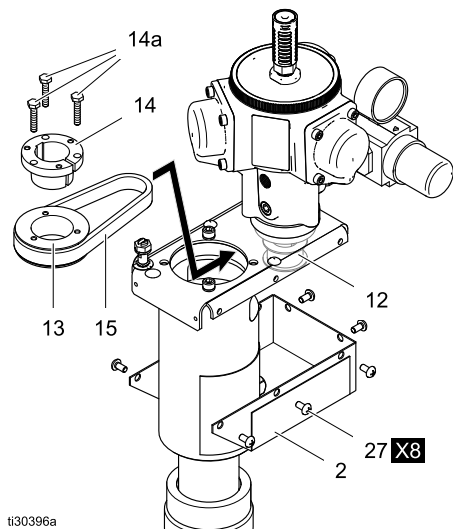

Ref.	Description
2	Belt Drive Cover
12	Small Pulley
13	Large Pulley
14	Bushing
14a	Hex Head Screw
15	Timing Belt
27	Pan Head Screw

Removing Siphon and Helix Tubes

1. Follow the [Pressure Relief Procedure](#), page 10.
2. Remove the seal bearing (8).
3. Remove the two diagonally placed socket-head screws (24) and lockwashers (25) protruding from the top of the siphon cover (6)
4. Remove the siphon tube (4) as follows:
 - a. Rest the agitator on its side on the drive belt housing (2) so the inlet is lower than the outlet. This orientation prevents fluid from running into the bearing and drive belt area.
 - b. Pull out on the union swivel (41) to remove the siphon tube.
5. Remove the three hex-head screws (14a) from the bushing (14), and install the screws into the bushing threaded holes. Tighten the screws evenly to loosen the bushing from the helix tube (7).
6. Pull the helix tube (7) from the bottom of the agitator housing (3).

Table 6 Removing Siphon and Helix Tubes

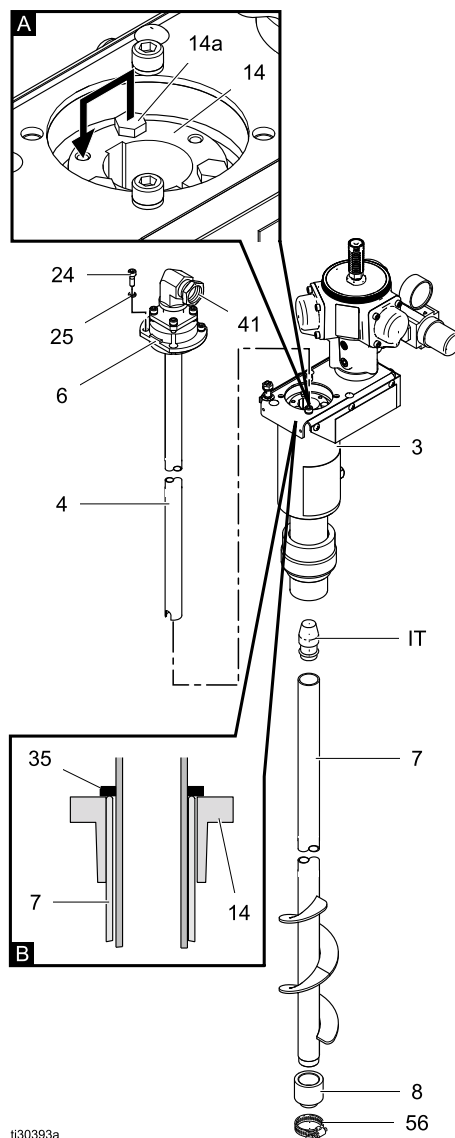

ii30393a

Ref.	Description
2	Belt Cover
3	Bracket
4	Siphon Tube
6	Siphon Cover
7	Helix Tube
8	Seal Bearing
14	Bushing
14a	Hex Head Screw
24	Screw
25	Lock Spring Washer
35	Thrust Washer
41	Union Swivel
56	Hose Clamp
IT	Installation Tool

Assembling the Agitator

1. Make sure the spacer (10) is in place. With its larger inside diameter taper facing up, install the larger pulley (13) and the drive belt (15) through the agitator housing. See [Removing the Drive Belt, page 14](#).
2. Slide the other end of the drive belt over the smaller pulley (12). The drive belt should not be tight after it is installed. Make sure the pulleys are aligned, then secure the small pulley (12) by tightening the setscrew. Torque setscrew to 45 to 55 in-lbs (5.1 to 6.2 N•m).
NOTE: The drive belt (15) should fit snugly — neither too tight or too loose. The belt design eliminates the need for high initial tension. After installation, it should take a force of 1.0–1.3 pounds to deflect the drive belt about 1/2".
3. Place the bushing (14) into the larger pulley (13).
4. Install the screws (14a) in the non-threaded holes in the bushing (14); do not tighten the screws yet.
5. Place the installation tool (IT) on the end of the helix tube. The installation tool is included with Shaft Seal Kit 236762.

NOTICE

Use the installation tool to insert the helix tube through the shaft seal to prevent damage to the seal lip.

6. Apply PTFE spray lubricant to the top 6 in. (150 mm) of the helix tube (7). While holding the pulley (13) down, push the helix tube and tool (IT) up through the bottom of the agitator housing (3) until the tube is flush with the top of the bushing (14). Remove the installation tool.
Wedge a screwdriver blade into the gap of the bushing (14) to spread the bushing while inserting tube (7).
7. Torque the three hex-head screws (14a) oppositely and evenly to 55 to 60 in-lbs (6.2 to 6.8 N•m).
8. Install the thrust washer (35) flush to the bushing (14).
9. Secure the drive belt cover (2) with the eight screws (27).
10. Apply PTFE spray lubricant to the top 6 inches of the siphon tube (4) inlet end only. Install the siphon tube through the top of the agitator housing (3).
11. Install the two socket-head screws (24) and lockwashers (25) into the top of the siphon cover (6). Torque the screws oppositely and evenly to 60 to 70 in-lbs (6.8 to 7.9 N•m).
NOTE: The helix tube (7) should move up and down about 0.05 inch (1.3 mm). If it does not, the bearings (11) are not fully seated. Push the bearings in until they are fully seated.
12. Apply PTFE spray lubricant to the inside lip of the seal bearing (8), and tighten it onto the helix tube (7).

Parts

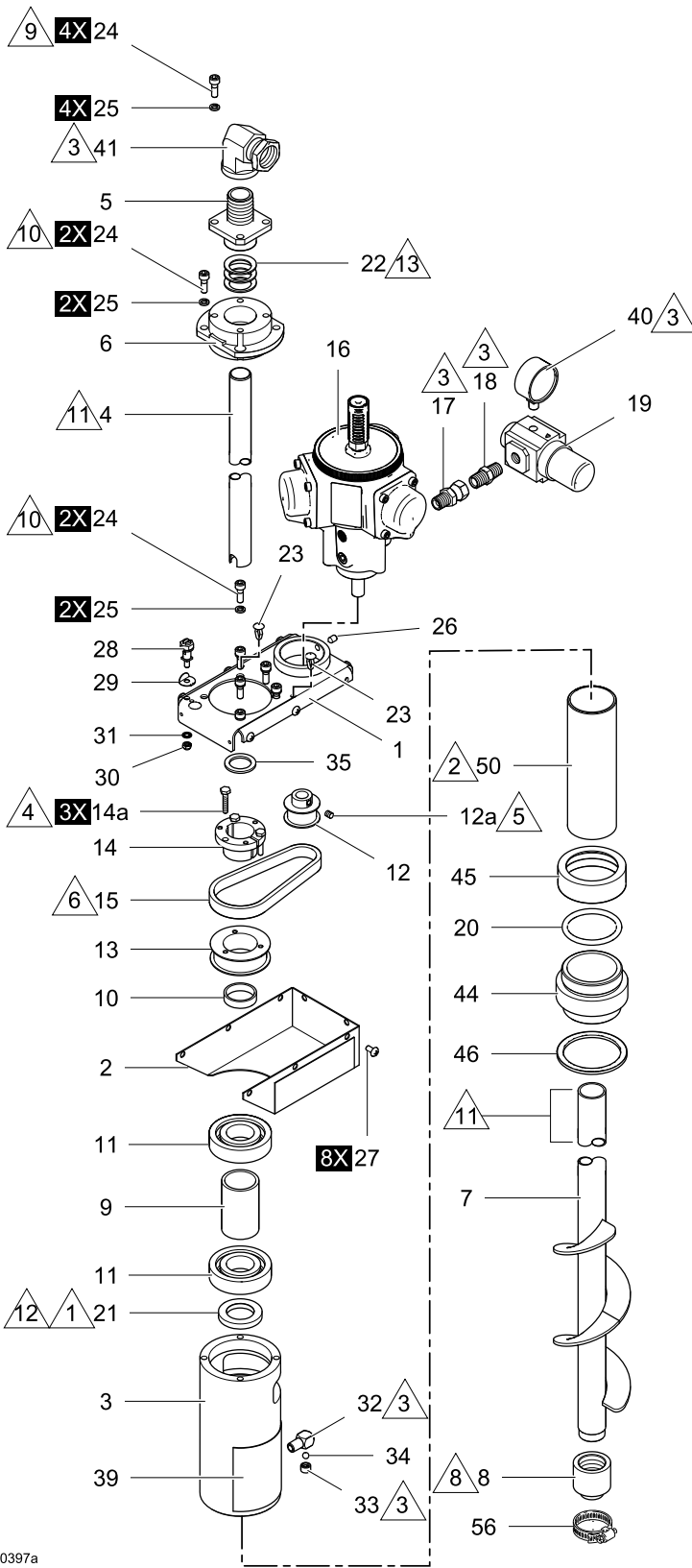

1	Press into place.
2	Apply high-strength thread sealant to threads.
3	Apply anaerobic PTFE pipe sealant to threads.
	Torque pulley clamp capscrews in sequence to 6.2–6.8 N•m (55–60 in-lbs) with tube (7) flush with top of clamp (14).
	Tighten pulley set screw after aligning pulleys. Torque set screw to 5.1–6.2 N•m (45–55 in-lbs).
	Timing belt must not be tight, with no belt tension after installation.
8	Place rings (22) with outer lips facing up.
	Bend tab of washer (29) up to lock.
	Apply PTFE spray lubricant to the siphon tube (4) inlet end and to the top 6 in. (150 mm) of helix tube (7) before you install them.
	Apply lube (49) to the siphon tube (4) before installing through items (8) and (21).
	On top fitting, torque cap screws in sequence stems to 9.0–11.3 N•m (80–100 in-lbs).
Follow recommended torque specifications found in the Installation section of this manual.	

ti30397a

Parts

Ref No.	Part No.	Description	Qty
1	236720	Bracket Assembly, Twistork Air Motor	1
2	189648	Cover, Belt, Drive	1
3	189649	Housing, Twistork	1
4	189651	Tube, Siphon	1
5	189653	Fitting, Siphon, Twistork	1
6	189654	Cover, Siphon, Twistork	1
7	236719	Helix Assembly	1
8†*	189655	Bearing, Seal	1
9	189656	Spacer, Bearing	1
10	189657	Spacer, Pulley	1
11	112548	Bearing, Ball	2
12	112549	Pulley, Belt, Small Timing	1
12a	— — —	Setscrew, pulley; 1/4 x 20 x 3/16 in.; not a replacement part	1
13	112550	Pulley, Belt, Large Timing	1
14	112551	Bushing, Lock, Taper	1
14a	— — —	Screw, hex head; #10-24 x 1 in.; not a replacement part	1
15*	112552	Belt, Timing; ESD rated/marked	1
16	25C765	Motor, Air, Rotary Piston; includes 17, 18, 19, and 40. See manual 3A5050 for motor rebuild kits and muffler kits.	1
17	156823	Fitting, Union, Swivel	1
18	156971	Fitting, Nipple, Short	1
19	116513	Regulator, Air	1
20*	112553	Packing, O-Ring	1
21†*	112555	Seal, Shaft, Lip, Ptfе	1
22*	195045	Ring, Tube Support, Sealing	3
23	111482	Rivet, Snap	2
24	112556	Screw, Cap, Socket Head	8

Ref No.	Part No.	Description	Qty
25	108050	Washer, Lock, Spring	8
26	112557	Screw, Set, Socket Head	1
27	106084	Screw, Mach, Pan Head	8
28	104029	Clamp, Ground, Electric	1
29	104582	Washer, Tab	1
30	105332	Nut, Lock	1
31	100718	Washer	1
32	100839	Fitting, Elbow, Street	1
33	189659	Seat, Valve, Check	1
34	105691	Bearing, Ball	1
35	189662	Washer, Thrust	1
36	198279	Label Kit, Blank	1
37	187830	Label, Identification	1
38	186620	Label, Symbol, Ground	1
40	104635	Gauge, Pressure, Air	1
41	112572	Swivel, Union, 90 Degree	1
44	178575	Adapter, Bung	1
45	178576	Retainer, O-Ring	1
46*	106537	Gasket, Bung	1
50	189650	Tube, Housing	1
56	110980	Clamp, Hose	1
60▲	17P806	Kit, Safety Tag (not shown); includes safety warning label and warning tag	1
▲ Replacement safety labels, signs, tags, and cards are available at no cost.			
† This part is included in Repair Kit 236762, which may be purchased separately. The kit also includes an installation tool, which is needed to insert the helix tube through the shaft seal without damaging the seal lip.			
‡ An optional Rulon bearing nut is available. Order Part No. 189660.			
* Keep these spare parts on hand to reduce down time.			

Dimensions

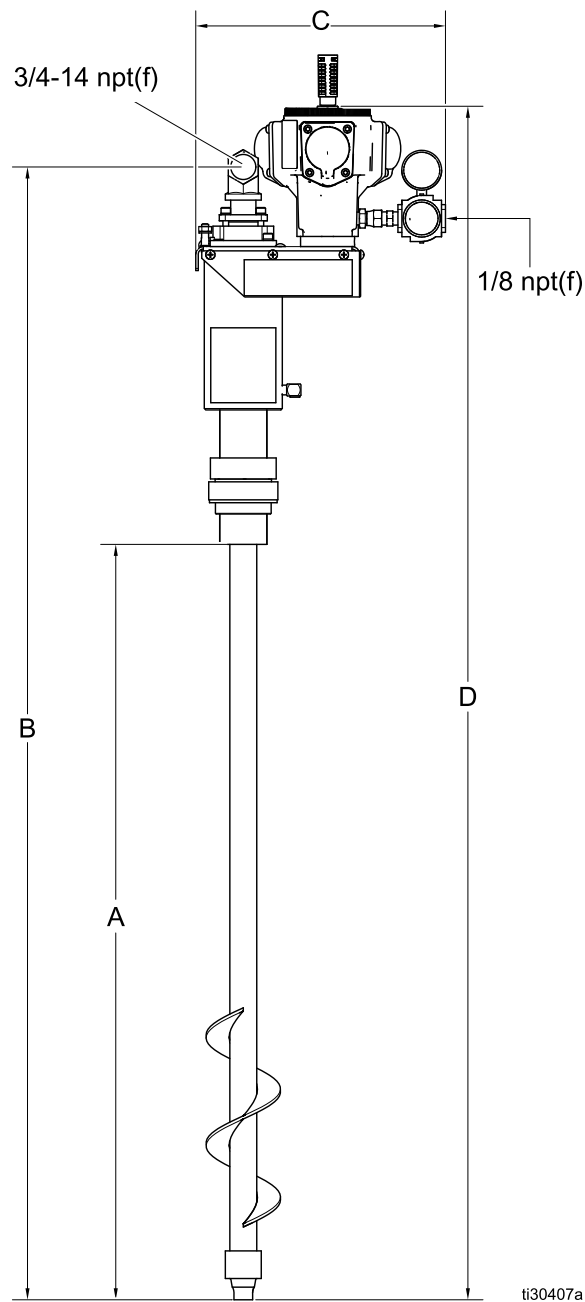

Reference	Dimension
A	31.5 in (79.9 cm)
B	47.7 in (121.2 cm)
C	10.4 in (26.4 cm)
D	49.7 in (126.3 cm)

Air Consumption

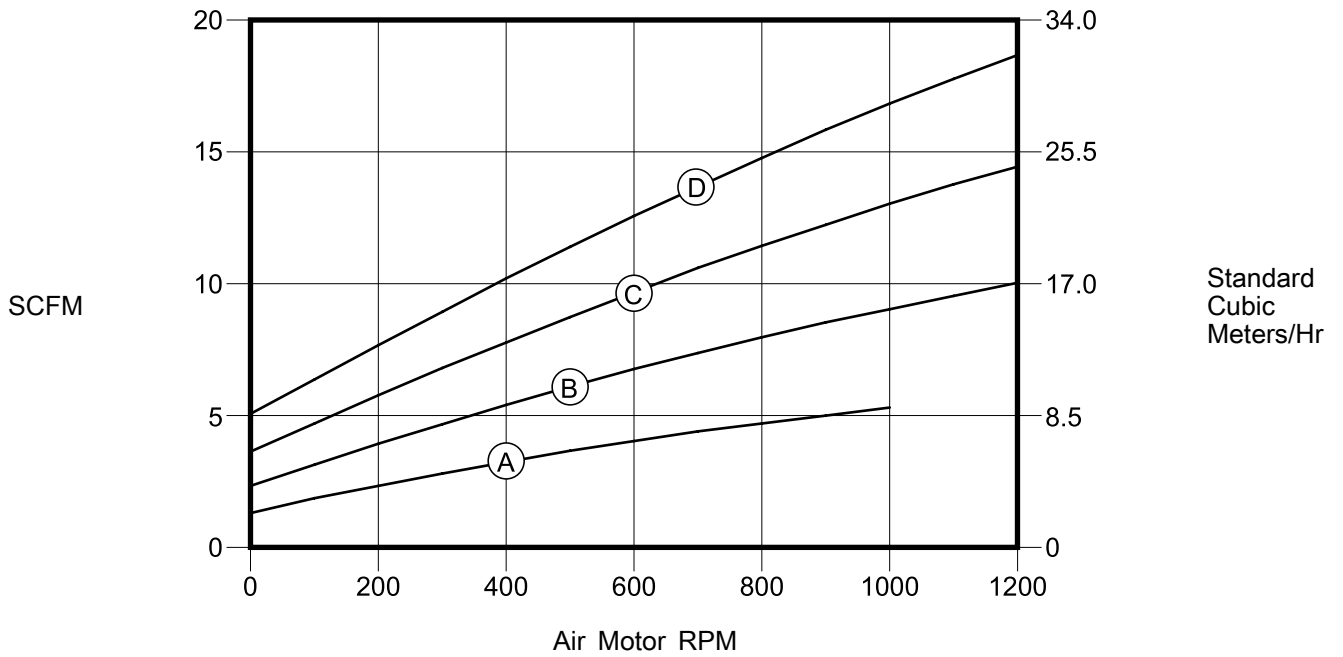

- A — 20 psi (1.4 bar, 0.14 MPa)
- B — 40 psi (2.8 bar, 0.28 MPa)
- C — 60 psi (4.1 bar, 0.41 MPa)
- D — 80 psi (5.5 bar, 0.55 MPa)

Technical Specifications

Twistork Helix Agitator — Stainless Steel, Bung Mount, Belt Drive	
Maximum Recommended Operating Pressure	70 psig (0.5 MPa, 5 bar)
Maximum Siphon Flow Rate	
with 100 centipoise material	approximately 12 gpm (45 lpm)
with 1000 centipoise material	approximately 1.2 gpm (4.5 lpm)
Air Consumption	See Air Consumption, page 20 .
Maximum Recommended Helix Speed	500 rpm
Maximum Allowable Process Fluid Temperature	122° F (50° C)
Maximum Recommended Material Viscosity	1000 cP
Wetted Parts	304 and 316 stainless steel, graphite-filled PTFE, acetal AF, Rulon(R)* LR
Weight	26 lb (11.8 kg)
Sound Pressure Level at 70 psig, Maximum Recommended Speed	Less than 75 dBA
*Rulon(R) is a registered trademark of Dixon, a division of Furon	

California Proposition 65

 **WARNING:** This product can expose you to chemicals known to the State of California to cause cancer and birth defects or other reproductive harm. For more information, go to www.P65warnings.ca.gov.

Graco Standard Warranty

Graco warrants all equipment referenced in this document which is manufactured by Graco and bearing its name to be free from defects in material and workmanship on the date of sale to the original purchaser for use. With the exception of any special, extended, or limited warranty published by Graco, Graco will, for a period of twelve months from the date of sale, repair or replace any part of the equipment determined by Graco to be defective. This warranty applies only when the equipment is installed, operated and maintained in accordance with Graco's written recommendations.

This warranty does not cover, and Graco shall not be liable for general wear and tear, or any malfunction, damage or wear caused by faulty installation, misapplication, abrasion, corrosion, inadequate or improper maintenance, negligence, accident, tampering, or substitution of non-Graco component parts. Nor shall Graco be liable for malfunction, damage or wear caused by the incompatibility of Graco equipment with structures, accessories, equipment or materials not supplied by Graco, or the improper design, manufacture, installation, operation or maintenance of structures, accessories, equipment or materials not supplied by Graco.

This warranty is conditioned upon the prepaid return of the equipment claimed to be defective to an authorized Graco distributor for verification of the claimed defect. If the claimed defect is verified, Graco will repair or replace free of charge any defective parts. The equipment will be returned to the original purchaser transportation prepaid. If inspection of the equipment does not disclose any defect in material or workmanship, repairs will be made at a reasonable charge, which charges may include the costs of parts, labor, and transportation.

THIS WARRANTY IS EXCLUSIVE, AND IS IN LIEU OF ANY OTHER WARRANTIES, EXPRESS OR IMPLIED, INCLUDING BUT NOT LIMITED TO WARRANTY OF MERCHANTABILITY OR WARRANTY OF FITNESS FOR A PARTICULAR PURPOSE.

Graco's sole obligation and buyer's sole remedy for any breach of warranty shall be as set forth above. The buyer agrees that no other remedy (including, but not limited to, incidental or consequential damages for lost profits, lost sales, injury to person or property, or any other incidental or consequential loss) shall be available. Any action for breach of warranty must be brought within two (2) years of the date of sale.

GRACO MAKES NO WARRANTY, AND DISCLAIMS ALL IMPLIED WARRANTIES OF MERCHANTABILITY AND FITNESS FOR A PARTICULAR PURPOSE, IN CONNECTION WITH ACCESSORIES, EQUIPMENT, MATERIALS OR COMPONENTS SOLD BUT NOT MANUFACTURED BY GRACO. These items sold, but not manufactured by Graco (such as electric motors, switches, hose, etc.), are subject to the warranty, if any, of their manufacturer. Graco will provide purchaser with reasonable assistance in making any claim for breach of these warranties.

In no event will Graco be liable for indirect, incidental, special or consequential damages resulting from Graco supplying equipment hereunder, or the furnishing, performance, or use of any products or other goods sold hereto, whether due to a breach of contract, breach of warranty, the negligence of Graco, or otherwise.

FOR GRACO CANADA CUSTOMERS

The Parties acknowledge that they have required that the present document, as well as all documents, notices and legal proceedings entered into, given or instituted pursuant hereto or relating directly or indirectly hereto, be drawn up in English. Les parties reconnaissent avoir convenu que la rédaction du présente document sera en Anglais, ainsi que tous documents, avis et procédures judiciaires exécutés, donnés ou intentés, à la suite de ou en rapport, directement ou indirectement, avec les procédures concernées.

Graco Information

For the latest information about Graco products, visit www.graco.com.
For patent information, see www.graco.com/patents.

To place an order, contact your Graco Distributor or call to identify the nearest distributor.

Phone: 612-623-6921 **or Toll Free:** 1-800-328-0211 **Fax:** 612-378-3505

All written and visual data contained in this document reflects the latest product information available at the time of publication.

Graco reserves the right to make changes at any time without notice.
Original Instructions. This manual contains English. MM 3A4548

Graco Headquarters: Minneapolis
International Offices: Belgium, China, Japan, Korea

GRACO INC. AND SUBSIDIARIES • P.O. BOX 1441 • MINNEAPOLIS MN 55440-1441 • USA
Copyright 2019, Graco Inc. All Graco manufacturing locations are registered to ISO 9001.